

Dismantling joint, ductile iron, DN 80-1200, PN 10/16, flanges.



General

- Dismantling joint designed to facilitate the removal of flanged valves from pipelines.
- Can increase and decrease the distance between valve and pipeline with max +/- 25 mm.
- Epoxy coated.
- Flanges according to EN 1092-2.

Options

- Other flange standards.
- PN 6, PN 25 and PN 40.
- Other materials.
- Bigger dimensions.
- Expansion joint (VM 3192-3193).

Materials

DN	80	100	125	150	200	250	300	350	400	500	600	700	800	900	1000	1200
Flanged pipe in ductile iron EN-JS1030	•	•	•	•	•	•	•	•	•	•	•	•	•	•	•	•
Retaining ring in steel EN 1.0038	•	•	•	•	•	•	•	•	•	•	•	•	•	•	•	•
Stud bolt in galvanized steel	•	•	•	•	•	•	•	•	•	•	•	•	•	•	•	•
Sealing ring in EPDM	•	•	•	•	•	•	•	•	•	•	•	•	•	•	•	•
Epoxy coating (FBE) RAL 5005, ≥ 250µm	•	•	•	•	•	•	•	•	•	•	•	•	•	•	•	•

(• = standard)

Technical Data

DN	80	100	125	150	200	250	300	350	400	500	600	700	800	900	1000	1200
Pressure rating PN 10 (VM 3182)	•	•	•	•	•	•	•	•	•	•	•	•	•	•	•	•
Pressure rating PN 16 (VM 3183)	•	•	•	•	•	•	•	•	•	•	•	•	•	•	•	•
Temperature range -15°C - +80°C	•	•	•	•	•	•	•	•	•	•	•	•	•	•	•	•

(• = standard)

In the interest of technical progress, designs and dimensions may be subject to change | VM 3182-3183 | 2011-06-20

Dimensional Drawing

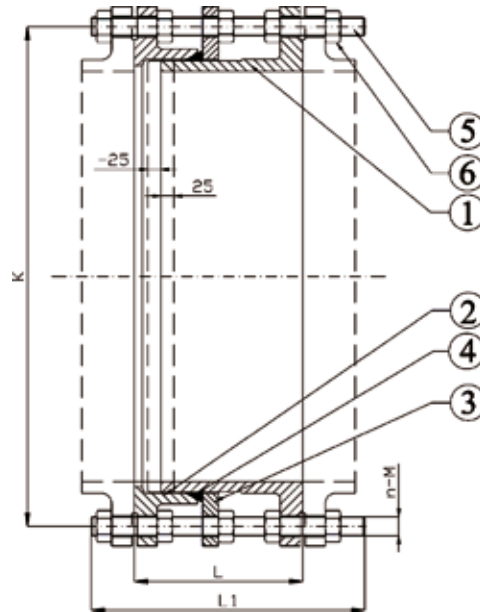

Details

- 1 Flanged pipe - long
- 2 Flanged pipe - short
- 3 Retaining ring
- 4 Sealing ring
- 5 Stud bolt
- 6 Nut

Dimensional Data (mm) and Weight VM 3182

DN	80	100	125	150	200	250	300	350	400	500	600	700	800	900	1000	1200
L	200	200	200	200	220	220	220	230	230	260	260	260	290	290	290	320
L1	350	350	350	350	380	380	390	400	410	460	460	460	500	500	510	570
n-M	8-M16	8-M16	8-M16	8-M20	8-M20	12-M20	12-M20	16-M20	16-M24	20-M24	20-M27	24-M27	24-M30	28-M30	28-M33	32-M36
K	160	180	210	240	295	350	400	460	515	620	725	840	950	1050	1160	1380
Weight (kg)	18	20	24	30	42	62	67	85	105	155	225	300	361	400	516	895

Dimensional Data (mm) and Weight VM 3183

DN	80	100	125	150	200	250	300	350	400	500	600	700	800	900	1000	1200
L	200	200	200	200	220	230	250	260	270	280	300	300	320	320	340	360
L1	350	350	350	350	380	400	420	440	460	490	520	520	550	560	600	650
n-M	8-M16	8-M16	8-M16	8-M20	8-M20	12-M20	12-M24	16-M24	16-M27	20-M30	20-M33	24-M33	24-M36	28-M36	28-M39	32-M45
K	160	180	210	240	295	355	410	470	525	650	770	840	950	1050	1170	1390
Weight (kg)	18	20	24	30	45	66	84	107	142	200	305	321	469	535	698	1070

Markings

The dismantling joint is marked with DN, PN, materials and producer.

Mounting

Optional.

We recommend using steel-reinforced rubber seals according to DIN EN 1514-1 Shape IBC. If you use raised face flanges these seals are mandatory.

Order Number

DN	VM 3182	VM 3183
80	3182080	3183080
100	3182100	3183100
125	3182125	3183125
150	3182150	3183150
200	3182200	3183200
250	3182250	3183250
300	3182300	3183300
350	3182350	3183350
400	3182400	3183400
500	3182500	3183500
600	3182600	3183600
700	3182700	3183700
800	3182800	3183800
1000	31821000	31831000
1200	31821200	31831200